

bWf FIRE DOOR ALLIANCE

BWF Fire Door Alliance
Fire Doors and Doorsets

Best Practice Guide



The BWF Fire Door Alliance



BWF Fire Door Alliance: The leading authority on fire door safety

A fire door is a vital safety device engineered to save lives and property.

The correct specification, supply, fitting and maintenance are critical and the responsibility of each and every person in the process.

It's only when a fire breaks out that the consequences of poorly manufactured or fitted fire doors are known.

This Best Practice Guide has been prepared by the British Woodworking Federation (BWF Fire Door Alliance) Fire Door Scheme. It is the complete reference source for everything that you and your customer need to know about third party certificated timber fire doors and doorsets.

Get it right = Protect Lives and Property

Get it wrong = Risk to Life and Property

Note: While every effort has been made to ensure the accuracy of advice given, the BWF cannot accept liability for loss or damage arising from the use of the information supplied in this publication.

Note: Other certification schemes adopt different marking options see www.firedoorsafetyweek.co.uk for further info.

The BWF Fire Door Alliance

The BWF Fire Door Alliance Fire Door and Doorsets Scheme

The BWF Fire Door Alliance was established in 2018 to draw together the Warringtonfire Certifire and BM TRADA Q-Mark third party certification schemes to promote the importance of using third party certificated fire doors and components as a critical part of any passive fire plan.



Regular testing and assessment of fire doors and components is necessary to ensure that products will perform in the event of a fire.

Scheme members operate strict, audited manufacturing control and supply systems and regularly fire test their products to ensure that they will perform if a fire breaks out. The audit ensures that processes are robust and effective training is in place to minimise risk.

The Scheme offers clear and simple methods of tracing a fire door and its components throughout the entire fire door chain.



The BWF Fire Door Alliance

It's all in the Label

The label provides traceability through the entire supply chain.

Labels should **NEVER** be removed from the door

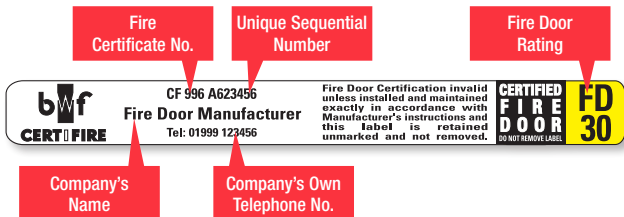

The label displays the member's name and phone number and the certification number. Each Prime Door Manufacturer and Licensed Processor label has a unique serial number and the door's fire rating.

Other labels associated with the BWF Fire Door Alliance:

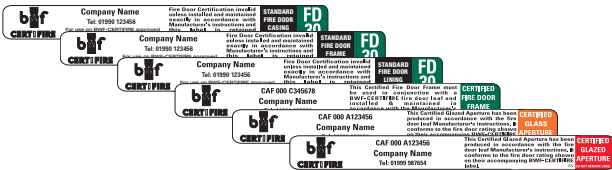

The Fire Door Chain – Who's responsible?

A critical chain of responsibility

- Raw Material and Component Supplier
- Manufacturer
- Processor
- Specifier
- Supplier
- Door Installer
- Door Inspection and Maintenance



**Don't be
the one**



**to break
the chain**

Using this guide

This guide is for anyone in the fire door supply chain, from raw material or component supplier, right through to the customer. It has been spilt up into sections to lead you through your responsibilities and actions at every stage of the process.

The Fire Door Process

- A Basic Introduction to Fire doors
- Design and Specification
- Ordering and Procurement
- Delivery and Storage
- Installation
- Use Maintenance and Inspection

This guide is accompanied by easy to use checklists and pictures to support at every stage of the process and help the user recognise areas of risk in the fire door chain.

Further information can be found at www.firedoors.bwf.org.uk



Close the door on Fire door Safety

Guide to Symbols

In addition, there are easy to recognise symbols to support you at every stage and highlight checks and risk areas.

Compliance Warning	
Check the Fire Certificate & Data Sheet	
Best Practice	
Safety Warning	
Component Compatibility	
Installation Instructions	
Top Tip	

Contents

1	A Basic Introduction to Fire Doors	9
2	Regulations	22
3	Design and Specification	34
4	Installation	49
5	Inspection and Maintenance	67
6	Useful tools and further information	74



Fire Doors A Basic Introduction

1

Fire Doors A Basic Introduction

What is a fire door?

A door must have fire test evidence to prove that it is a fire door.

This evidence could be in the form of test reports, assessment reports or third party certification documentaiton.

A fire door must be tested by or the results of tests verified by an independent test organisation in accordance with British or European Standards.

Installed and maintained correctly, it will perform in the event of a fire.

The best way to prove to your customer that you have supplied a fire door is by a current fire certificate of approval issued by a third party certification scheme, proving that testing is relevant to the supplied product and has been done by an independent accredited third party.

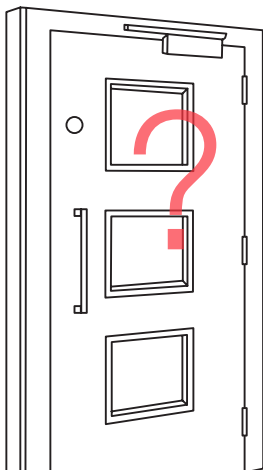

Fire Doors

A Basic Introduction

1

What happens if you get it wrong?

Manufacturing, installing or maintaining fire doors incorrectly results in 5 main **Risks**:

- Danger for users of the building and possible loss of life
- Danger for emergency services responding to a fire
- You could be prosecuted resulting in a fine or imprisonment
- Property and possessions will not be protected
- Risk to reputation



What do fire doors actually do?

Fire doors act as a barrier to a fire, cutting off and protecting parts of a building.

- Reducing the damage caused by fire and smoke
- Protecting evacuation routes
- Providing the emergency services with a protected route to access the building
- Protecting users of a building who may have difficulty evacuating quickly

Fire doors are a vital part of the building fabric, dividing the building into individual fire compartments, constructed and lined with suitable fire resisting materials to reduce the spread of fire.

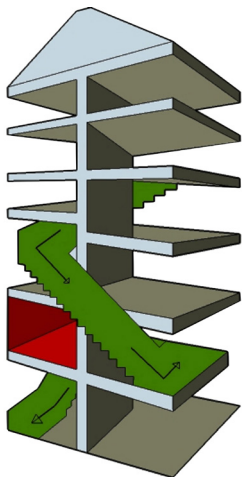

BEST
PRACTICE



SAFETY
WARNING



TOP
TIP



Fire Doors

A Basic Introduction

1

What makes a fire door work?

In the event of a fire the following elements are critical to making sure a fire door performs in a fire.

- ✓ Door leaf
 - ✓ Frame / lining
 - ✓ Intumescent seals
 - ✓ Smoke seals*
 - ✓ Latch or lock
 - ✓ Hinges
 - ✓ Door closer*
 - ✓ Signage*
 - ✓ Other ironmongery*
 - ✓ Fire door glazing*
 - ✓ Frame / wall sealing
 - ✓ Threshold seals*
 - ✓ Air transfer grille (ATG)*
- (*if required)

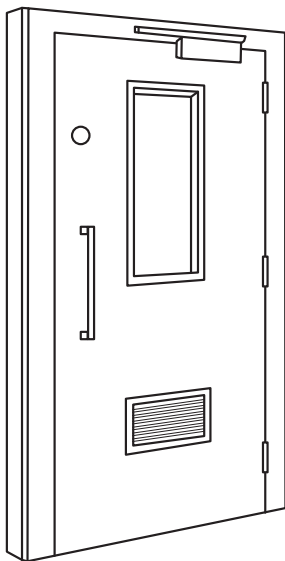

Get just 1 thing WRONG =

High chance of Failure = Loss of Life or Property



COMPLIANCE
WARNING



CHECK THE FIRE
CERTIFICATE



BEST
PRACTICE



SAFETY
WARNING



COMPONENT
COMPATIBILITY



INSTALLATION
INSTRUCTIONS



TOP
TIP

Component Definitions

- Door leaf* The fire door leaf is the main component of the doorset or door assembly and is usually manufactured to a range of standard sizes and door styles. Fire doorset performance is demonstrated by the manufacturer's test evidence, assessment reports or certification documents
- Frame/Lining or Casing* The frame design, size, fixings and material is critical to the fire performance and fire rating.
- Intumescent seals* Intumescent seals are located in the door edge or frame, these seals expand in the event of a fire and seal the gap between door and frame, stopping the passage of fire. The gap between the frame is often between 2 & 4mm but can be greater where supported by test evidence. Excessive gaps may prevent intumescent seals performing correctly in the event of a fire.
- Smoke seals** Combined with, or separate from intumescent seals and located in the perimeter of the frame or door edge. These wipe or compression seals restricts the flow of smoke. Remember: Smoke Kills.
- Fire door glazing** Some fire doors have vision panels fitted in them. Special fire tested glass and glazing systems must be used. This operation should only be undertaken by a trained and competent individual, with a good working knowledge of the specific materials and glazing systems required.
- Threshold seals** Threshold seals are located on the bottom of the door or threshold, they seal the gap under the door to prevent the flow of smoke and the passage of fire.

Fire Doors

A Basic Introduction

1

Component Definitions

- Signage** Correct fire door signage should be fitted on all non-domestic fire doors at eye level.
- Hinges* A minimum of 3 fire rated hinges must be used with correct intumescent pads, location and fixings.
- Door closer** Some fire doors are fitted with closers to ensure the fire door always returns to its fully closed position and is held in the closed position when not in use.
- Latch or lock** When fitted, the latch or lock engages the door leaf securely to the frame when the door is in the closed position. It is critical in securing the door in the event of a fire and preventing warping of the door.
- Air transfer grilles** Fire rated air transfer grilles are fitted into some doors to keep fresh air circulating within a building, combining air movement with fire protection. In everyday use, air can pass freely through the grilles to allow good ventilation. In a fire, the intumescent expands, fusing the grille into a solid mass that stops fire spreading. Some fire rated Air Transfer Grilles combine fire with cold smoke protection, using an electro mechanical shutter plate system that closes on fire alarm activation, preventing the spread of deadly smoke and fumes. Fire only rated Air Transfer Grilles should not be used on doors designated FD30S and FD60S; in these doors, the combined fire and cold smoke dampers must be used.

*if required

All components must be right and listed on the Door Fire Certificate or Data Sheet to ensure performance.



Definitions - Fire Doorset

'...complete unit consisting of a door frame and a door leaf or leaves, supplied with all essential parts from a **single source**'.
BS EN 12519

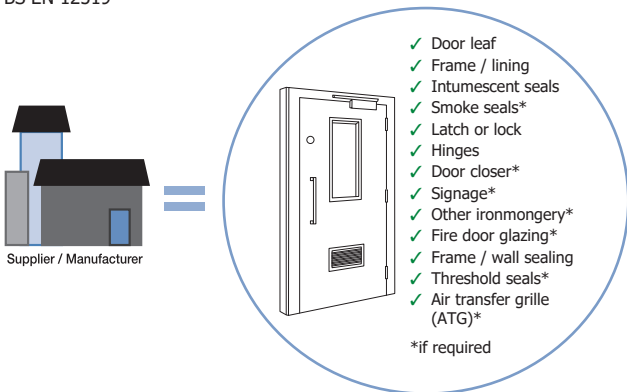

This means that it is supplied as a **complete unit from one supplier**.

- Fully fitted up and finished, direct from the manufacturer
- Fitted with all compatible components and glazing
- Pre-assembled in the factory

This ensures that the entire doorset and components will match the manufacturer's test evidence, assessment reports or certification documents

When the whole doorset is supplied in individual component parts for assembly on site, this is often referred to as a door kit.



Fire Doors

A Basic Introduction

1

Definitions - Fire Door Assembly

'...complete assembly as installed, including door frame and one or more leaves, together with its essential hardware supplied from 'separate sources'. BS EN 12519

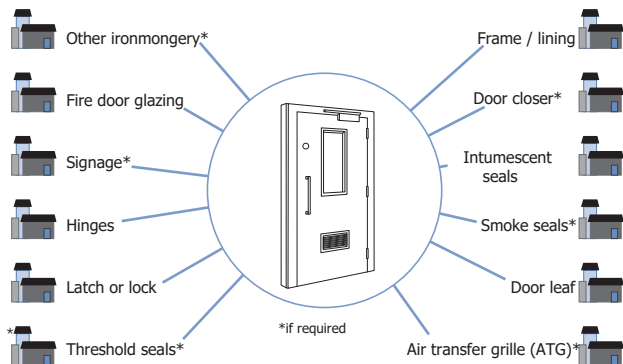

This means that the components can be sourced from many **different manufacturers or suppliers.**

To make sure that the door assembly works, it must be:

- Only altered as defined in the manufacturer's test evidence, assessment reports or certification document.
- Fitted with compatible components as per installation instructions, and
- The compatible components must be listed on the door leaf manufacturer's test evidence, assessment reports or certification document.



Door configuration

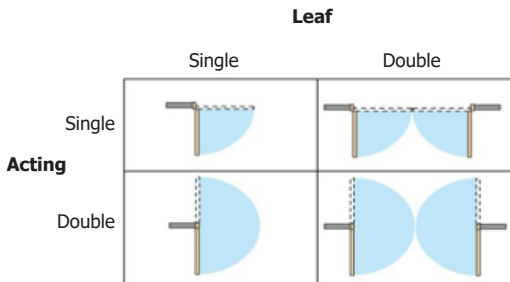

Configuration describes whether a door is single or double leaf and what direction the door opens.

Not all doors can be fitted in a double configuration as different intumescent seals and/or different ironmongery may be required.



Always check the manufacturer's test evidence, assessment reports or certification document or contact the door manufacturer to make sure the correct specification is used in the correct configuration.



Glazed Apertures and Apertures for Air Transfer Grilles (ATG) and Other Ironmongery

Apertures are cut in door leaves for a variety of reasons; to accommodate a glazed fixed light, air transfer grilles or other ironmongery such as letterplates.

Apertures can vary in dimension, fire rating, location, size, shape and specification of compatible components.

Different types of fire resisting glass

Classification	Definition
----------------	------------

Integrity (E)	Stop the passage of fire and smoke
---------------	------------------------------------

Radiation (EW)	As integrity (E) but also offers some reduction in heat transfer to the non fire side.
----------------	--

Integrity and Insulation (EI)	As integrity but also offers significant reduction in heat transfer from the fire side to the non-fire side
-------------------------------	---

Cutting apertures and fitting of fire rated components or glazing systems in a fire door is a highly skilled operation that should be carried out only by a trained person, ensuring the correct materials are used.

The allowed size, shape and compatible materials and components are detailed on the primary fire test report, assessment or third party certification document.

Always order your glazed door direct from a suitably certificated manufacturer or licensed processor to ensure performance. BWF Fire Door Alliance members are trained, audited and certificated to undertake this task.

Never cut apertures, or fit vision panels or air transfer grilles on site, you will invalidate any certification.

Fire Doors A Basic Introduction

Fire door rating

Fire door rating = Classification from results indicating the minimum period a fire door assembly is expected to resist fire when subjected to a test

Tested to BS 476-22 or EN 1634-1.

UK ratings are given below, with the minimum period of time the fire door will resist fire in a test.

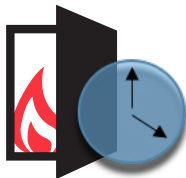

British Standard: Minimum fire resistance (integrity) rating	European Standard: Minimum fire resistance (integrity) rating	Minimum number of minutes the door should resist fire
FD 30	E 30	30 minutes
FD 60	E 60	60 minutes
FD 90	E 90	90 minutes
FD 120	E 120	120 minutes

All BWF Fire Door Alliance door and frame components will indicate their fire rating on the label or on an accompanying plug.

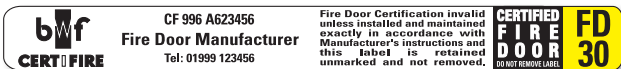

Fire doors are different to **fire and smoke** control doors.



Fire Doors

A Basic Introduction

1

Fire and smoke control doors

Sometimes doors are required to be both fire and smoke control doors. Tested to BS 476-31.1 or EN 1634-3 for the passage of smoke at ambient temperature

This means there will be either a combined fire and smoke seal or separate intumescent and smoke seals fitted into either the edge of the door leaf and/or the frame.

If an air transfer grille (ATG) is fitted in the door leaf, it will contain an automatic smoke damper that will close if a fire breaks out.

The 'S' suffix (e.g. FD30S) denotes that the door is both a fire and smoke control door.

British Standard: Minimum fire resistance (integrity) rating	European Standard: Minimum fire resistance (integrity) rating	Minimum number of minutes the door can resist fire and cold smoke
FD 30S	E 30Sa	30 minutes
FD 60S	E 60Sa	60 minutes
FD 90S	E 90Sa	90 minutes
FD 120S	E 120Sa	120 minutes

Always check the gap between the door and frame (top, bottom & edges) and manufacturer's test evidence, assessment reports or certification document to ensure smoke seals will perform. The gap between the frame is critical and smoke seals must fill this gap when the door is closed. Excessive gaps will prevent smoke seals performing correctly in the event of a fire.





Fire Door Regulations

2

Building Regulations

The Building Regulations provide guidance as to the **minimum** building standards to be achieved. They reference the relevant British and European Standards defining the test requirements and performance of the fire door assembly or fire doorset.

A building designer or owner may choose to fit fire doors in other locations than specified in the regulations to further protect life and property and reduce risk.

There are regional variations of the Building Regulations.

English & Welsh Building Regulations = Approved Documents

Building Regulations in Scotland = Technical Handbooks

Northern Ireland = Technical Booklets.

Note: England & Wales have separate Approved Documents. please check those local to you for guidance



Building Regulations relating to fire safety

	England and Wales	Scotland	Northern Ireland
Fire Safety	Approved Document B	Technical Handbook 2	Technical Booklet E



Other Building Regulations

Different Building Regulations detail other construction elements and performance relating to fire doors.

	England	Wales	Scotland	N Ireland
Fire Safety	B	B	2	E
Sound	E	E	5	G
Ventilation	F	F	3	K
Thermal	L	L	6	F
Accessibility	M	M	3	R
Safety	K	K	4	V
Security	Q	Q	4.13	

The full Building Regulations guidance documents are available to download from:

England: www.gov.uk/government/collections/approved-documents

Wales: www.gov.wales/building-regulations-approved-documents

Scotland: www.gov.scot/policies/building-standards/monitoring-improving-building-regulations/

Northern Ireland: www.dfpni.gov.uk/index/buildings-energy-efficiency-buildings/building-regulations/br-technical-booklets.htm

Fire Door Regulations

The following information is based on English Building Regulations. The Regulations in Northern Ireland, Scotland and Wales contain some differences.

Approved Document B – Fire Safety

The regulation and guidance affecting fire doors is contained in Approved Document B, Volumes 1 and 2.

These specifically cover fire safety guidance for buildings in which fire doors play a critical role in fire safety.

2

Part B is split into 2 sections:

Volume 1: Dwellings

Volume 2: Buildings other than Dwellings



Where should fire doors be fitted?

Fire Doors are required in an increasing number of buildings built in the UK according to the relevant national fire safety regulations.

Requirement, rating and location of fire doors is different for different types of buildings and is based on:

- Guidance for compliance with the relevant building regulations.
- The overall fire risk assessment* and plan (including escape routes).
*if applicable.

It should be noted that beyond regulation, specification also drives requirement and insurance companies often place specific fire door requirements on projects. This is discussed in the following section.

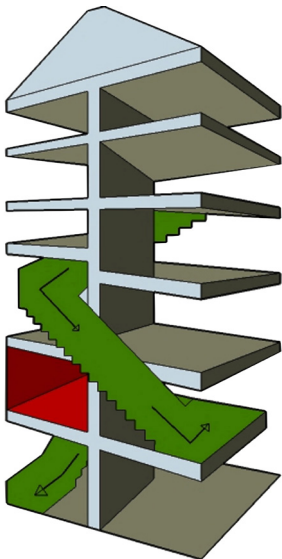

COMPLIANCE
WARNING



BEST
PRACTICE



TOP
TIP



Dwellings (Part B - VOLUME 1)

Fire doors are required:

- In a cavity barrier (wall) where applicable
- Above two levels, every door leading to the stairwell (at all levels). Where the door leads to a habitable room which have fire rated separating walls
- When a property has a loft conversion
- Between house and integral garage
- Between the business and residential elements in a mixed-use building

Note that this list is not exhaustive and other locations may require fire doors depending on the layout, use and fire plan of the individual dwelling.

Buildings other than Dwellings (Part B - VOLUME 2)

Fire doors are required in many different non-domestic buildings such as:

- Schools
- Hospitals
- Flats
- House of Multiple Occupancy (HMO)
- Nursing Homes
- Hotels
- Public Buildings
- Offices
- Warehouses
- Entertainment Venues
- Factories and more...



2



The location and rating of fire doors will be based on the Fire Risk Assessment (FRA), design and layout of the particular building with consideration to the user's particular needs.

The FRA must always be carried out by a competent, trained and qualified individual. See Section 6.

Flats (Part B - VOLUME 1)

Fire doors are required:

- Front door of individual flats
- Within individual flats to stop the spread of fire between rooms
- Other locations depending on the layout, use, fire risk assessment and fire plan of the individual building



Fire Rating of Doors in the Building Regulations

Approved Document B identifies the rating of the door (e.g. FD30, FD60 etc.).



The guidance refers to the use of 20 minute fire doors (FD20) in some circumstances.

The BWF Fire Door Alliance does not provide labelling for 20 minute fire doors. The majority of member manufacturers produce 30 minute doors as a minimum and we are not aware of any specifications to this requirement.

2

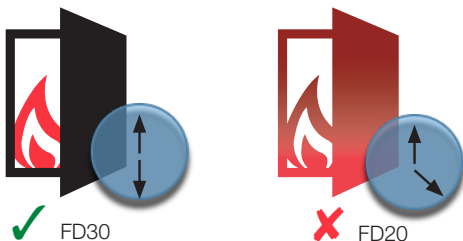

The Building Regulations refer also to E30 or E30 Sa etc. This refers to product tested to the European test methods (EN1634 Part 1 or EN 1634 Part 3) rather than the British Standards.



Regulation 38 and handover

Regulation 38 applies in England and Wales and states that fire safety information must be handed to the **'responsible person'** at the completion of a project, or when the building or extension is first occupied.

It places the responsibility of fire safety onto the **'responsible person'**.

In order for the responsible person to carry out future inspections and maintenance of fire doors, it is important that the correct information such as installation and maintenance instructions and traceability to the Fire Certificate is handed to them.

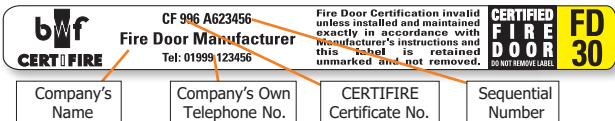

The fire door label provides that **traceability**.

Use this simple checklist to ensure you have the correct information at handover.

Regulation 38 Checklist

- ✓ Location and rating of every fire door in the building
- ✓ The fire door certificate – which **MUST** be relevant to the installed fire door*
- ✓ The type of seal (intumescent/smoke seal/acoustic) fitted to the door or frame
- ✓ Details of the door frame (hardwood, softwood, MDF etc.) and how that relates to the fire door certificate
- ✓ Details of the door leaf design and whether it contains specialist vision panels or ironmongery, such as letterplates or air transfer grilles, and how that relates to the fire door
- ✓ Details of hinges, closers and other essential building hardware (CE marked) and how that relates to the fire door certificate
- ✓ Maintenance information for each component, including the door leaf
- ✓ Frequency of inspection and maintenance, where required.

Don't break the Fire door chain

Regulatory Reform (fire safety) order (FSO or RRO)

The Regulatory Reform (Fire Safety) Order 2005 or RRO, came into force in 2006.

The responsibility for fire risk assessment in **all non-domestic buildings**, including the common parts of flats and houses of multiple occupation, falls to the designated '**responsible person**'.

The responsible person must carry out a fire safety risk assessment and implement and maintain a fire management plan. The law applies to you if you are:

- Responsible for business premises
- An employer or self-employed with business premises
- Responsible for a part of a dwelling where that part is solely used for business purposes
- A charity or voluntary organisation
- A contractor with a degree of control over any premises
- Providing accommodation for paying guests

Failure to comply with the FSO or RRO can place property and lives at risk and is likely to result in criminal prosecution.

Complying with the FSO or RRO= It's the law!

Note: The responsible person has the meaning given by article 3 of the Regulatory Reform (Fire Safety) Order 2005

Construction (Design and Management) Regulations 2015 (CDM 2015)

The revised CDM (2015) identifies responsibilities of designers and suppliers in regard to the safety of construction products that are supplied and installed. Construction companies will need to provide information, instruction, training and supervision, with workers having their training needs assessed against the needs of the job and employers to meet the gap in skills knowledge through appropriate training.

Crucially if you supply **fire door assemblies or doorsets** the new CDM regulations may make it your responsibility to provide safety information regarding the use of a product throughout its installation and service life. This would include installing a product correctly and providing installation and maintenance instructions to the building manager or customer in order for them to be able to inspect and maintain the fire door product safely.

*The designer's role when preparing or modifying designs is to **eliminate, reduce or control foreseeable risks** that may happen during construction or maintenance and use of a building **after it's been built**. The designer also provides information to other members of the project team to help them fulfil their duties.*

Source: Industry Guidance for Designers on CDM: CITB

CE marking

CE marking is required under the Construction Products Regulation (CPR) which applies to construction products that are made available on the market within Europe.

The CE label and Declaration of Performance (DoP) state product performance in the following fields (where applicable).

1. Mechanical resistance and stability
2. Safety in case of fire
3. Hygiene, health and the environment
4. Safety and accessibility in use
5. Protection against noise
6. Energy economy and heat retention
7. Sustainable use of natural resource

CE marking of Fire doorsets: It has been possible to CE mark external fire rated door sets since November 2016 and it became mandatory in November 2019. External doors acting as escape doors fitted with escape hardware must be CE marked.

CE marking does not apply to interior door sets at this time and it is not possible to CE mark door assemblies or door leaves. In isolation CE marking does not offer the full advantages of certification, particularly in terms of traceability, information to support maintenance and interchangeability of components.

CE marking of fire door hinges: Must be tested to BS EN 1935, should be used on fire or smoke doors and on all escape routes.

CE marking of door closing devices: Overhead and electromagnetic closing devices and door co-ordinators tested to BS EN 1154/55/58 has been required since 2004.

CE marking of Panic and escape hardware: Panic and emergency exit devices intended for use on escape route doors can be CE marked and will be tested to either EN 1125 or EN 179

Check for other CE marked hardware (e.g. locks and latches)



Fire Doors Design and Specification

3

Sticking to the Specification – It's Critical



Building contractors are pressured to be on time and on budget. Cheaper untested products may save the client money, but if a fire breaks out, it will cost far more in lives and property.

It's straightforward:

Stay safe, Save lives and Stick to the Specification

By compromising the original specification, a fire door installation risks catastrophic failure in the event of a fire. This is discussed in the following section.

There are four major areas where contractors and their clients are at risk:

- Non-compliance with Building Regulations
- Non-compliance with the Regulatory Reform (Fire Safety) Order
- Lack of adequate insurance protection
- Insufficient protection for life or property



How to prove it

By using compatible products and suppliers, in accordance with the Fire Certificate and installation instructions, you can provide evidence of compliance of a fire the fire performance of a fire door assembly or doorset to your customer.

The scheme label that is attached to the product provides:

- A Unique Identification Number
- The Fire Certificate Number
- The Fire Door Rating
- Contact details of the manufacturer or processor of the product

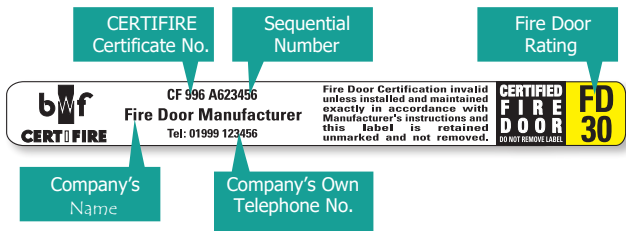

How to provide evidence

The label demonstrates to your customer **bwf** **FIRE DOOR ALLIANCE** or building control that the product has been certified by a third party, and as long as it has been correctly installed and maintained, it will perform in the event of a fire.

Unless a door is regularly inspected and adequately maintained, it may over time start to present a safety risk – using certificated products helps to support CDM requirements.

The Certifire Fire Certificate can be downloaded from the product register: www.warringtonfire.com/certified-companies/certifire and apply the relevant filters to find the manufacturer.

You can also find details of Q-Mark Manufacturers at www.bmtrada.com/certified-companies

A list of scheme members, who manufacture and supply certificated products can be downloaded from: www.firedoors.bwf.org.uk/publications/guides-and-directories/



	CF 996 A623456 Fire Door Manufacturer Tel: 01999 123456	Fire Door Certification invalid unless installed and maintained exactly in accordance with Manufacturer's instructions and this label is retained unmarked and not removed.	CERTIFIED FIRE DOOR DO NOT REMOVE LABEL	FD 30
--	---	---	---	--------------

Design and Specification

The early stage of the design and specification of fire doors and doorsets can present a challenge to avoid costly mistakes.

Major insurance companies typically insist on the use of third-party certificated passive and active fire protection products.

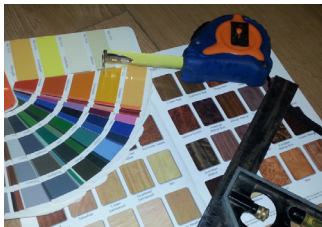

The RISCAuthority Design Guide: Essential Principles (No.5) states:

“As a minimum, all fire protection products shall be third party certified to an appropriate product - or performance-based standard”.

Many people CLAIM to sell fire doors but many of them cannot provide acceptable evidence to back up their claims.

By specifying BWF Fire Door Alliance products in tender documents, ensures that the product is manufactured under strict factory production control systems and regularly fire tested to ensure consistency of quality and fire performance.



Compatibility of Components

Definition: Compatibility

All components have either been tested with the door and frame and has passed the fire test or an assessment has been made on the original test evidence. Compatible components are listed on the fire door certificate.

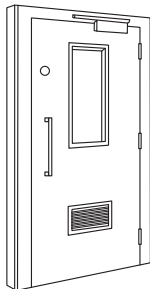

- ✓ Door leaf
- ✓ Frame / lining
- ✓ Intumescent seals
- ✓ Smoke seals*
- ✓ Latch or lock
- ✓ Hinges
- ✓ Door closer*
- ✓ Signage*
- ✓ Other ironmongery*
- ✓ Fire door glazing*
- ✓ Frame / wall sealing
- ✓ Threshold seals*
- ✓ Air transfer grille (ATG)*

*if required



Different elements and variables in a fire door assembly or fire doorset

Frame, lining or casing

The frames, linings or casings can be supplied with pre machined or separate door stops and are wide ranging in design, finish and specification. If supplied separately the doorstop is correct to the frame / lining and the Fire Certificate.

Common frame, casing and lining profiles:



The MOST important things are that:

- Frame or lining is COMPATIBLE* with the door leaf and ironmongery and is correctly rated to suit the door
- The frame or lining is the correct size and material
- The frame or lining is suitable for use with the intended wall type
- Installation instructions are supplied
- It is a requirement that fire door frames are compatible with the test evidence, assessment or certification documents. It is possible to provide certificated frames under Certifire. Certificated frames must carry a BWF-Certifire label.



Choosing ironmongery

The ironmongery that is fitted to fire doors is wide ranging in type, design, fire rating, finish and specification.

The MOST important things are that:

- Ironmongery is COMPATIBLE* with the door leaf and frame and is correctly fire rated to suit the fire door
- Where required The ironmongery is CE marked for fire performance. (See section 2)
- The ironmongery is supplied with installation instructions
- The correct fixings are used

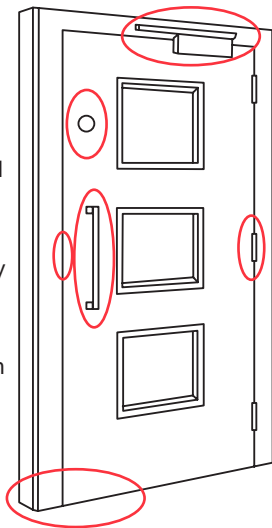

*COMPATIBLE definition: All the ironmongery has been tested with the door and frame and has passed the fire test or has been assessed as compatible based on fire test evidence. Compatible ironmongery is detailed on the door certificate

Ironmongery - additional intumescent pads / material

Most ironmongery requires additional intumescent protection by pads or mastic unless specified by the door Fire Certificate.

Compatible ironmongery will provide detail within the packaging of the specification, size and location if additional intumescent protection is needed.

Where required, intumescent materials should be fitted in accordance with the installation instructions.



GAI Code of Practice. Hardware for fire and escape doors. Issue 4, 2012.

www.firecode.org.uk/



Choosing intumescent and smoke seals

The intumescent and smoke seals that are fitted to fire doors are wide ranging in size, intumescent material, colour and specification.

They can be supplied separately or combined as one seal.

They can be located in the door edge or frame

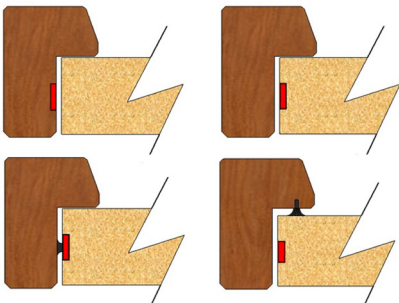

The MOST important things are that:

- Seals are COMPATIBLE* with the door leaf and frame and correctly fire rated
- The correct gap (as specified in the instructions) is achieved between the door and the frame

*COMPATIBLE definition: All seals have been tested with the door and frame and has passed the fire test or has been assessed as compatible based on fire test evidence. Compatible seals are detailed on the door certificate

Choosing the door leaf

Fire door leaves are available in a very wide range of surface finish and material to suit every style or budget.



A fire door must NEVER have an aperture cut or be glazed on site as this is a highly skilled operation and should only be carried out by trained and competent personnel. Specify any apertures at point of order to ensure compliance with the Fire Certificate.

Cutting apertures or glazing a fire door leaf on site will invalidate any certification. This work must be carried out by a suitably certificated organisation and evidenced by the application of a Scheme glazing label or plug.

The MOST important things are:

- The door leaf is COMPATIBLE* with the ironmongery, frame, seals and is correctly rated
- Any glazing is carried out by a the original door manufacturer or a licensed processor and carries the appropriate plug or label
- Installation instructions are provided
- The door leaf is BWF Fire Door Alliance approved.

	CAF 000 A123456	<small>This Certified Glazed Aperture has been produced in accordance with the fire door leaf Manufacturer's instructions. It conforms to the fire door rating shown on their accompanying BWF-CERTIFIRE label.</small>	
	Company Name		
	To: 01999 987654		

Writing tender documents

The tendering process is an area where mistakes can often happen and specification gets broken. If you are responsible for writing tender documents for the procurement of fire doors, the following information is useful to include:



- All doors, frames and associated ironmongery and components must be CE marked and tested for fire performance where applicable
- All doors, frames and associated ironmongery and components must be COMPATIBLE* and detailed on the Fire Certificate
- All products must be installed by a competent installer in accordance with the installation instructions and Fire Certificate

Scheme members can be found on the "Find a Supplier" page of the BWF Fire Door Alliance web site



Specification Checklist - Doorsets

Guidance on measuring the frame opening is found in Section 6

Doorset Location		Important to make sure the correct door assembly is fitted in the correct location.
Fire and/or smoke rating		As prescribed in the building regulations, legislation and client specification.
Actual structural opening size	Height	*see guidance for frame opening – section 6
	Width	
	Depth	
Actual frame height	Height	*see guidance for frame opening – section 6
	Width	
	Depth	
Frame material and finish		All elements must be detailed on the Fire Certificate data sheet to prove performance and compatibility. By specifying BWF Fire Door Alliance approved door sets you are ensuring compatibility and performance.
Door material and finish		
Intumescent size and specification		
Ironmongery requirement and finish		
Threshold requirement		
Vision panels or other ironmongery such as ATG's or letterplates, that require factory preparation and / or fitting		
Installation and maintenance instructions		
Third party Certification	Always ask for third party certificated products with a current Certificate	By specifying BWF Fire Door Alliance approved door sets you are ensuring compatibility and performance.

Specification Checklist - Door Assemblies

Guidance on measuring the opening is found in Section 6

Door Assembly Location		Important to make sure the correct door assembly is fitted in the correct location.
Fire and/or smoke rating		As prescribed in the building regulations, legislation and client specification.
Actual structural opening size	Height	*see guidance for frame opening – section 6
	Width	
	Depth	
Actual frame height	Height	*see guidance for frame opening – section 6
	Width	
	Depth	
Frame material and finish		All elements must be detailed on the Fire Certificate data sheet to prove performance and compatibility.
Door material and finish		
Intumescent colour		
Ironmongery requirement and finish		
Threshold requirement		
Vision panels or other ironmongery such as ATG's or letterplates, that require factory preparation and / or fitting		By specifying BWF Fire Door Alliance approved door assemblies you are ensuring compatibility and performance.
Installation and maintenance instructions		Always ask for instructions for fitting and maintaining.
Third party Certification	Always ask for third party certificated products with a current Certificate	By specifying BWF Fire Door Alliance approved door assemblies you are ensuring compatibility and performance.

Procurement

Once you have confirmed your design and specification, the next step is to buy your fire door assembly or doorset.

Due diligence

You or your company should demonstrate due diligence by only using certificated products.

Checks should be built into your process to ensure that the specification detailed on the Fire Certificate matches the supplied door.

Using certificated products is the only way to ensure a product has been adequately tested, the Fire Certificate gives specific information about the specification and performance of the product and suitable information is made available to support the installer and maintenance teams to ensure that the door continues to meet the required standards throughout its service life, helping to fulfill CDM requirements.

Avoiding False Claims from suppliers

Beware of false claims from suppliers.

The only way to ensure fire performance is if the door has been tested and holds a current Fire Certificate produced by a suitable accredited third party.

Finding a Supplier

By using BWF Fire Door Alliance Members you can ensure that product supplied will be compatible, hold a current Fire Certificate and will be supplied with installation instructions.

Scheme members can be found on the "Find a Supplier" page of the BWF Fire Door Alliance web site





Fire Door Installation

4

Why fire door installation matters

Installation of fire doors is as life critical as the product specification itself and should only be carried out by someone who is competent, has been specifically trained to install fire doors and understands their responsibilities in getting it right.

Always follow the manufacturer's installation instructions to maintain certification.

Fire doors that are incorrectly installed and fitted with incompatible components invalidate certification and will not provide adequate protection for occupants of the building.

For further information about fire door installation, refer to the BWF Fire Door Alliance Installation Guide.



Buying the door

Check your product at point of purchase, collection or delivery

- ✓ Check product is undamaged
- ✓ Check for the BWF Fire Door Alliance CERTIFIRE label
- ✓ Check that the order is correct and complete and all compatible components of the assembly or doorset have been delivered
- ✓ The specification should call for the moisture content of the timber components to be close to that which the doorset will experience in service.

NOTE – ORDER THE RIGHT DOOR: Altering the door for glazing apertures and air transfer grilles or resizing outside of the parameters on the certificate will make certification **VOID**.



Delivery

- Fire doors are heavy. Make sure that there is sufficient labour to handle doors and components
- Ensure that employees are trained in manual handling heavy objects
- Door assemblies or doorsets must be lifted evenly and securely to avoid any bending or damage of components or frames
- Protective wrapping should be kept in place as long as possible
- Paint grade doors should be sealed and primed on all faces and edges immediately after delivery. Do not paint over the label



Reference: The Manual Handling Operations Regulations 1992 (as amended) apply to work which involves lifting, lowering, pushing, pulling or carrying.



Storage

Top tip:

Do not store in damp or exposed areas or near standing water, in direct sunlight or areas where there may be exposure to significant heat.



Doors should be:

- Stored flat, on a level and dry surface and kept clear of the floor on at least three level and robust bearers
- Protected from dirt and damage but without restricting air circulation
- Stacked so that they are not exposed to daylight as ultra violet light can cause fading or discolouration of timber and veneers
- Stored in the sequence they will be fitted to avoid double handling
- Avoid dragging them across each other in the stack
- Doorsets with projecting sills must have spacers between them in the stack to avoid damage



Care of fire doors on site (pre installation)

Moisture content of timber doors

For long term performance of the door and finish, the appropriate moisture content must be maintained during storage on site and during the construction process.

Rapid changes in moisture content and humidity can affect the product.

Product should only be installed once the site conditions are suitable and similar to the conditions that the product will experience in service.

- Ensure that the moisture content of the product is kept close to the level at which it was when the door was manufactured. Internal doors should be conditioned slowly to the service conditions before fitting
- Protect from abnormal heat, extreme dryness, humid conditions or sudden changes of temperature or humidity
- Do not store or fit in the building until the wet trades are finished and the building has dried out

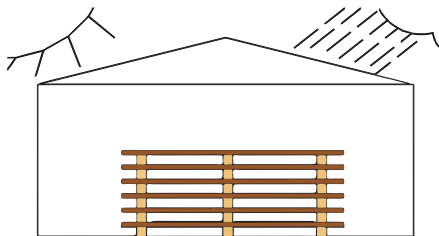

Prefinished Doors

- Factory finished door frames or door linings should ideally be fitted into pre-formed openings and not built into masonry walls
- Pre-finished doors should retain their protective packaging until the latest possible time, ideally until after internal decorations have been completed
- If it is necessary to separate the doors from doorsets, each door and frame should be given an identification mark so that the correct door is returned to the correct frame

Finishing the edges of fire doors

Changes in moisture content can affect the size and shape of a door and all edges (sides, bottom and top) should be coated to prevent moisture from penetrating the timber.

Note: The label should not be painted over.

Finishing doors on site

- Decoration should be started as soon as possible after delivery, doors with factory applied primer should have at least one of the finishing coats applied as soon as possible after delivery or installation
- The back of external frames should be coated before installation
- Ensure surfaces and edges are in good order before applying finishing coats
- Ensure all surfaces and edges are painted
- The edges should be coated before fitting the door
- The label that identifies the fire door must NOT be painted over
- Damaging or defacing the label will result in the door no longer being accepted as a fire door

For additional and specific guidance for your product, contact your fire door supplier.

Pre installation checklist

Wall type: Of suitable fire resistance for the fire door assembly or doorset rating.	✓
Installation Instructions: You have the relevant installation instructions from the manufacturer.	✓
Gap between the wall and the frame behind the architrave: You have suitable materials and intumescent materials and mastics to fill the gap as detailed on the installation instructions or Fire Certificate data sheet.	✓
Door leaf: Suitable for the fire door rating. Free from damage. Label/s on top of door undamaged.	✓
Door frame: Free from damage. Suitable for the fire door rating. Compatible with the door assembly or doorset. Label/s on frame (if applicable) undamaged.	✓
Fire and smoke seals: Free from damage. Suitable for the fire door or smoke rating. Compatible with the door assembly or doorset.	✓
Fixings: You have appropriate fixings for the frame, hinges, lock, latch and other ironmongery as specified by the manufacturer.	✓
Ironmongery: Supplied with correct intumescent pads. Supplied with fitting instruction. CE marked for fire performance where applicable. Hinges free from damage. Suitable for the fire door rating. Compatible with the door assembly or doorset.	✓
Vision panels or other apertures cut in the door leaf for ironmongery such as letter plates or air transfer grilles: Check all ironmongery, glass, glazing beads, seals and intumescent materials are free from damage and secured to the door.	✓
Label: Check door label/s in place.	✓
Health and safety: You have carried out a thorough risk assessment of the installation process and limited any risks.	✓
Competency of workforce: Ensure your workforce are suitably trained and qualified to install fire doors.	✓

Pre installation contd.....

- Clean the location of fitting
- Carry out a risk assessment and method statement regarding installation

Installation

Doors should be installed in accordance with the installation instructions provided with every BWF Fire Door Alliance door leaf or doorset.

If you have queries about your door, contact the fire door manufacturer. Details can be found on the fire door label on the top or side edge of the door.

RISCAuthority DESIGN GUIDE: ESSENTIAL PRINCIPLES (No.6) states 'All fire protection products or systems shall be installed by appropriately trained specialist installers'.

Ensure that those fitting the fire door assembly or doorset are correctly trained, specifically about fitting fire doors, and understand their responsibilities

Always follow the installation instructions to maintain certification.

Some suppliers may reference this in a separate installation document, while others will supply this information in the Certifire Fire Certificate data sheet.

The sequence for installation described on the following pages is, fit the frame, size and fit hardware to the door leaf, offer the door leaf into position and mark the location of the hinges, recess either the leaf or frame for the intumescent seals, recess for the hinges in the frame. Hang the door leaf then mark and cut the location of the keeps in the frame. This is an example and other sequences could be employed on site



Fire Door Installation

Installation process of a fire door

Always follow the installation instructions

Fitting the Frame

1. Locate frame in aperture.
2. Ensure the frame is square, straight and level.
3. Using suitable length, location, number of and specification of fixings, fix the frame in the aperture as specified in the installation instructions. Packers should be applied behind fixings. Only use packers that have a proven performance, having been successfully incorporated in an accredited fire door test
4. Check the frame is securely fixed on all sides.
5. Measure the frame aperture size to ensure the frame is straight, square and level and will fit the intended door with specified gap on all sides.
6. Check that the gap between the frame and the wall is completely sealed with fire stopping material that has a proven performance in successful fire tests, taking into consideration the substrate on either side of the gap (e.g. timber and masonry) the width of the gap and the thickness of the fire door frame (e.g. 70mm for typical softwood frame with 30 minutes fire resistance). A combination of materials (e.g. Intumescent mastic capping mineral wool) may be required to provide resistance to the passage of smoke as well as fire stopping for smoke control doors.

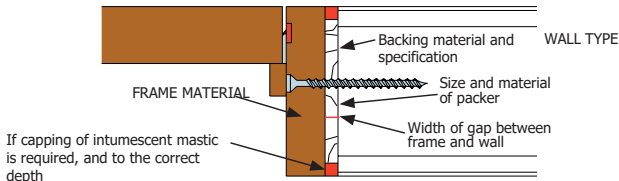

Points to consider when selecting the appropriate linear gap sealing system

Door leaf

Before you hang the door leaf (only applicable to a door assembly)

Always follow the installation instructions to maintain certification.

Size: A door leaf should only require minor resizing to fit the frame. Check the installation instructions for the maximum amount of material that can be removed.

Material should only be removed from the top of the door leaf as specifically instructed by the manufacturer. The label/s should not be removed, damaged or repositioned as this will invalidate certification.

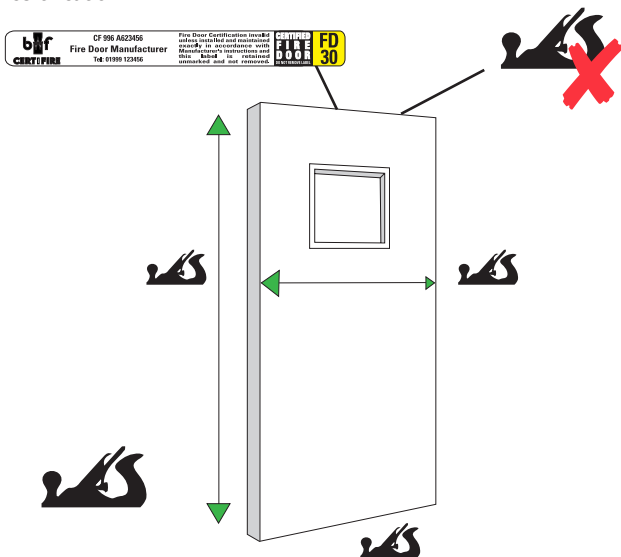

Hinges

1. Recess the door edge for the correct number of hinges to the correct size and location.
2. Pilot holes should be drilled at each fixing point, at the correct size and depth, to ensure the timber does not split.
3. Fix hinges using the recommended length, size and specification of screw.
4. Ensure that intumescent pads are used under both hinge blades if specified in the installation instructions.

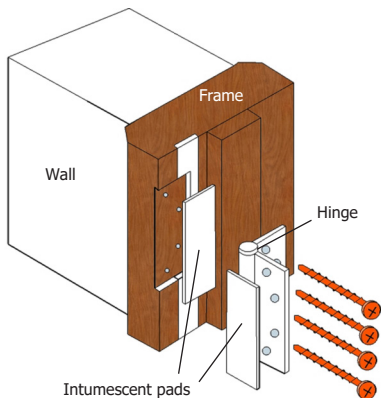

Lock or latch

1. Recess in the door edge for the lock or latch to the correct size.
2. Fix using the recommended length, size and specification of screw. Pilot holes should be drilled at each fixing point, at the correct size and depth, to ensure the timber does not split. Do not over-tighten the screws.
3. Repeat above in the frame for the keep.
4. Ensure that the correct intumescent material or intumescent mastic is used with the lock or latch if specified in the installation instructions and Fire Certificate data sheet.



Intumescent, smoke and / or threshold seals

Fire and smoke seals can be located in the frame and/or the door edge as per the door manufacturer's test evidence.

1. The frame or door should be grooved to take the suitable seal size and number of seals depending on the door's fire rating and configuration.
2. The groove must be smooth, clean and free of dust.
3. Seals should be cut to full length and fitted securely, flush into the groove.

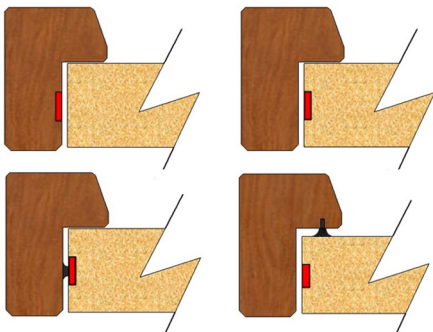

Hanging the door leaf

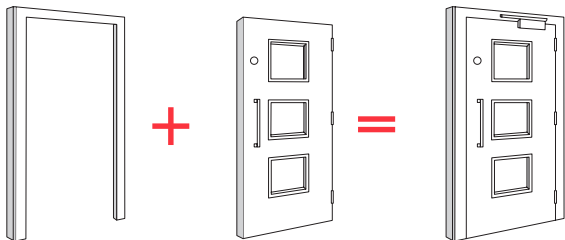

1. Position the door in the frame and mark where the hinges are located.
2. Recess in the frame for the correct number of hinges to the correct size.
3. Fix the hinged door leaf to the frame using the recommended length, size and specification of screw. Pilot holes should be drilled at each fixing point, at the correct size and depth, to ensure the timber does not split.
4. Ensure that intumescent pads are used under the hinge blades as specified in the installation instructions.
5. Test the door opening and closing action and ensure a smooth action.
6. Check the door closes level and straight against the stop on the frame.
7. Check that any smoke seals fill the gap around the perimeter of the door or frame.

- Only once all dimensional and functionality checks of the door have taken place, should backfilling of any further gaps between the backface of the frame and the wall be done. Intumescent material and intumescent mastic as specified in the installation instructions or the Fire Certificate data sheet should be used to fill any gaps, and only once this installation detail has been checked, architrave should be fitted.

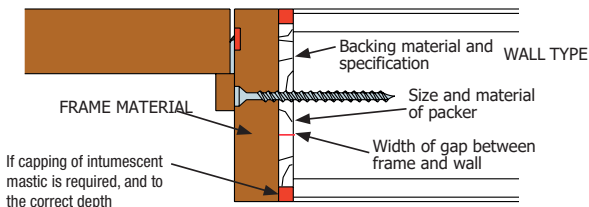

Points to consider when selecting the appropriate linear gap sealing system

4



Fitting the lock or latch keep and any additional ironmongery

1. Position the door in the frame and mark where the keep is located.
2. Recess in the frame for the keep to the correct size.
3. Fix using the recommended length, size and specification of screw. Pilot holes should be drilled at each fixing point, at the correct size and depth, to ensure the timber does not split.
4. Ensure that intumescent pads are used under the keep if specified in the installation instructions.
5. Test the door opening and closing action to ensure a smooth movement and complete, secure engagement of lock or latch.

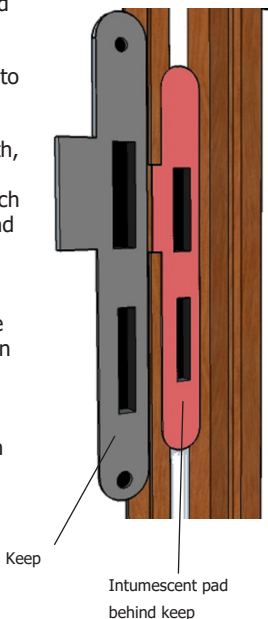

Post Installation Checklist

Door leaf <ul style="list-style-type: none">• Free from damage• Fitting plumb level and square in frame• Consistent gap between door and frame (as specified on Fire Certificate)• Label/s on top of door undamaged	✓
Door frame <ul style="list-style-type: none">• Free from damage• Suitable for the fire door rating• Compatible with the door assembly or doorset• Label/s in rebate are undamaged• Correct number of, specification, size and location of frame to wall fixings	✓
Fire and Smoke seals <ul style="list-style-type: none">• Compatible with the door assembly or doorset• Suitable for the fire door or smoke rating• Intumescent seals are full length in door edge or frame• Seals are flush in grooves• Smoke seal fills the gap between the door and the frame on all sides• Free from damage• Compatible with the door assembly or doorset	✓
Latch or lock <ul style="list-style-type: none">• Suitable for fire door rating• CE marked for fire performance• Engages securely with the keep in the frame or lining• Suitable for the fire door rating• Compatible with the door assembly or doorset• Fitted with correct intumescent pads if specified in the installation instructions	✓
Hinges <ul style="list-style-type: none">• Fitted with correct intumescent pads if specified in installation instructions• Fitted with the hinge manufacturers fixings that have been supplied and fire tested• CE marked for fire performance where applicable• Fitted with correct fixings (specification and length)• All fixings in place• Free from damage• Suitable for the fire door rating• Compatible with the door assembly or doorset	✓
Door closer (if required) <ul style="list-style-type: none">• Fitted with correct intumescent pads if specified in the installation instructions• CE marked for fire performance where applicable• Fitted with correct fixings (specification and length)• All fixings in place• Free from damage• Suitable for the fire door rating• Compatible with the door assembly or doorset	✓
Signage <ul style="list-style-type: none">• Check that the correct signage is in place and securely fixed to the door	✓

Post Installation Checklist contd.

<p>Other ironmongery</p> <ul style="list-style-type: none"> • CE marked for fire use on fire doors where applicable • Fitted with correct intumescent pads if specified in the installation instructions • Fitted with the ironmongery manufacturers fixings that have been supplied and fire tested • Fitted with correct fixings (specification and length) • All fixings in place • All components free from damage • Suitable for the fire door rating • Compatible with the door assembly or doorset 	✓
<p>Vision panels or other apertures cut in the door leaf for ironmongery such as letter plates or air transfer grilles</p> <ul style="list-style-type: none"> • Check all ironmongery, glass, glazing beads, seals and intumescent materials are free from damage and secured to the door • Check for the glazed aperture label or plug at the top of the door to prove that the door is glazed with compliant materials and glazing systems by a trained door processor • Site cutting of apertures and on site glazing is not permitted 	✓
<p>Gap between the wall and the frame behind the architrave</p> <ul style="list-style-type: none"> • Suitable materials, intumescent materials and mastics have been used to fill the any gap as detailed on the installation instructions or the Fire Certificate data sheet 	✓
<p>Gap</p> <ul style="list-style-type: none"> • Check the gaps between door leaf and frame (top, bottom & sides) are correct to installation instructions 	✓
<p>Wall type</p> <ul style="list-style-type: none"> • Of suitable type (e.g. masonry, steel stud etc.) and fire resistance for the fire door assembly or doorset rating 	✓
<p>Threshold seals</p> <ul style="list-style-type: none"> • When the door is closed the threshold seal (if fitted) engages fully and across its entire length 	✓
<p>Handover of documentation to prove fire performance</p> <ul style="list-style-type: none"> • Check the label/s are in place on the top or edge of the door and/or the frame. • Installation instructions • Maintenance instructions • Refer to the CF / CAF number on the label • Fire certificate (CF) if applicable • Contact manufacturer if further information is required 	✓
<p>Label / Plug</p> <ul style="list-style-type: none"> • In place, correct, undamaged 	✓



Fire Doors Inspection and Maintenance

5

Regular Inspection

Article 17 of the Regulatory Reform (Fire Safety) Order 2005 (RRO/FSO) makes it a legal requirement to ensure that fire resisting doors and escape doors are correctly installed and adequately maintained in order for them to be fit for purpose.

The authorities have the power to enforce the RRO/FSO and do prosecute or even close buildings down where breaches are discovered.

Building owners need 'responsible persons' as referenced in the RRO/FSO to help them comply with fire door regulations.



COMPLIANCE
WARNING



BEST
PRACTICE



TOP
TIP



Fire Doors

Inspection and Maintenance

Fire door register

Many buildings will have a fire door register that records information and the history about each individual fire door. The fire door register is important as it provides a central hub for all the relevant information about the fire doors within a building.

It is a useful register for a building owner or responsible person to prove to authorities that regular inspection and maintenance has occurred. The type of information that the register will include:

Door identification number	0000001*
Door location	Flat 3 entrance door*
Fire or fire and smoke rating	FD60S*
Door manufacturer	XXXX
Fire Certificate (CF) number	CF (number)
Configuration	Single acting, single opening*
Installation date	DD/MM/YY*
Installed by (name and company name)	XXXX*
Frequency of inspection and maintenance cycle	3 months*

Note: *Indicates example of type of information recorded. This list is not definitive and should be further developed by the user for a particular need, building or location and in accordance with any Fire Risk Assessment.



Inspection and Maintenance

Fire doors should be regularly inspected for damage that may prevent the door from performing in the event of a fire. This may form part of the risk assessment for the building.



Any issues should be fixed as soon as possible using compatible, correct fire rated components. The selection of suitable components is supported by the Fire Certificate and door schedule.

To check compatibility of components, always check the Fire Certificate data sheet or contact the fire door manufacturer.

By not using compatible components as listed on the Fire Certificate, fire certification of the door will be invalidated.

All parts of the door assembly or doorset should be inspected by a competent person

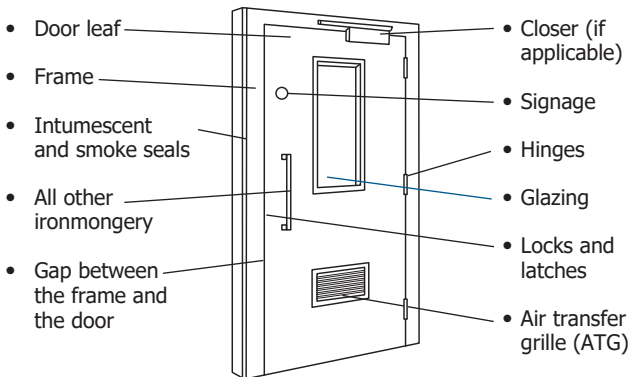

Frequency of Inspection

- Periodic checks should be carried out at least once every six months
- Newly occupied buildings may require more frequent checks in the first year of use
- Doors where traffic is high are likely to be more susceptible to damage and should be checked more frequently than other doors in the building. E.g. once per week/month (depending on usage).



Inspection checklist for resident or homeowner

Door leaf and frame <ul style="list-style-type: none">• The door and frame is fitted securely, square and level.• There is no distortion between the stiles, top and frame. The gaps between door and leaf must not be greater than those specified in the manufacturer's installation instructions or Fire Certificate data sheet• Damage to door leaf or frame	
Intumescent fire and smoke seals <ul style="list-style-type: none">• Good condition• Full length and secure in groove• If seals are badly fitted, damaged, (or in the case of smoke seals) painted, they must be replaced with exactly the same size and intumescent material that was originally specified. Some standard intumescent seals can perform once painted, but it is not best practice and you should always refer to the manufacturer• If the smoke seals have to be replaced, then they should be fitted in one continuous length if possible	
Locks and lever handles <ul style="list-style-type: none">• Lock levers fully return to the horizontal after use• Latchbolt is engaging smoothly and completely into the keep• Wipe any metal dust deposits off the latchbolt and keep• Adjust, lubricate or replace as per manufacturers recommendation	
Hinges <ul style="list-style-type: none">• No visible wear, dark marks or stains around the hinge knuckle could indicate wear and impending failure	
Closing and opening devices <ul style="list-style-type: none">• Open the door fully and check it closes without binding on the floor• Open the door to approximately 5 degrees and again check that it closes fully, engaging any latch or seal• Check door closing speed to be approximately 10 seconds from 90 degrees and ensure that the door does not slam• Ensure that doors are not being wedged open• Make sure that door hold-open devices are not straining the doors against their self-closing devices• Ensure that doors on hold-open devices fully close when released - this should be checked daily• Check that mechanical hold-open devices have not been fitted• Hold-open devices on fire doors should be electro-magnetic, and connected directly to the fire detection and alarm system and/or power failure so that they can be released automatically if there is a fire or power failure. This should be checked weekly	
Mandatory safety signs <ul style="list-style-type: none">• Signs have not been damaged or removed	

Fire Doors

Inspection and Maintenance

<p>All ironmongery</p> <ul style="list-style-type: none">• All fixings are secure and in good condition• Some hinges, closer arms and locks might require lubrication and/or adjustment – refer to manufacturer recommendations	
<p>Apertures in the door leaf (glazed, air transfer grille, other ironmongery such as letter plates)</p> <ul style="list-style-type: none">• Glass is not cracked or broken• Glazing beads securely in place and undamaged• Air transfer grille or other ironmongery fitted in apertures in the doorleaf is secure, fire rated and in good condition	
<p>Cleaning</p> <ul style="list-style-type: none">• Cleaning of Fire doors should be as per the manufacturer's instructions.	
<p>Check the label and check the gap between the doorleaf and the frame and the threshold gap</p> <ul style="list-style-type: none">• Always check for the label• Find it on top of the door, or just below the bottom hinge on a doorset• Never tamper with the label• Never paint over the label• A damaged or non-existent label invalidates certification• If the label is damaged contact the manufacturer directly and inform them so they can act accordingly	 A close-up photograph showing a person's eyes looking through a rectangular label on a fire door. The label has the word 'Wipacaster' printed vertically on the left side and other technical markings on the right. The person's face is partially visible through the label's opening.

Remember:

The full inspection and maintenance of a fire door can only be carried out by a trained and competent professional.

If you need to replace parts or components, you must use like for like and check that the correct, compatible components are listed on the installation instructions or Fire Certificate data sheet.

Remember: Use the manufacturer contact details on the label if you are unsure what replacement components are correct.

If you fit incompatible and incorrect components the certification of the door will be invalidated.



Fire Doors Useful Tools and Further Information

6

How to measure the structural opening for a fire door assembly or doorset

Some fire door manufacturers will carry out a site survey to measure the opening in the wall and ensure that a correctly sized door and components are supplied.

However, if you are measuring the opening, the following list provides some points to consider.

Step 1: Measure the WIDTH of the aperture at the top, middle and bottom of the opening

Step 2: Measure the HEIGHT of the aperture on the left, middle and right hand side of the frame.

Step 3: Measure the depth of the opening (the wall thickness) at different points around the frame.

Other considerations: Sometimes site measuring is undertaken when the build is part way through and not all of the elements that lead to accurate dimensioning will be obvious. If you are measuring the aperture, check for finished floor heights and wall thickness. This information will also be available from architectural drawings.

Measure twice, cut once

There is no harm in checking measurements twice, prior to ordering. It will pay off in the long run.

Installation tolerances

Once you have measured the aperture, you should subtract at least 5 mm from the smallest width measurement and 5 mm from the smallest height measurement to give an installation clearance.

This dimension is known as the FINISHED FRAME SIZE.

It is important to allow a fitting clearance to ensure that the frame and door can be fitted squarely and level into the aperture without bending the components.

Non square or uneven apertures

Sometimes an aperture can be uneven and measure differently. The aperture size that you specify must be the SMALLEST measurement that is taken.

You MUST NOT cut material away from the fire door frame to make it fit.

Contact information

BWF Fire Door Alliance - Fire Door & Doorset Scheme

www.firedoors.bwf.org.uk



Certifire Certification

www.warringtonfire.com/certification-services/fire-certification/certifire



BM TRADA Q-Mark Fire Door Certification Scheme

www.bmtrada.com/certification-services/third-party-certification-fire/q-mark-fire-door-manufacture-scheme



Gap Testers

BWF Fire Door Alliance Gap testers are available by contacting the British Woodworking Federation.



Publications

Fire Door Alliance Factcards

www.firedoors.bwf.org.uk/publications/fact-cards/

Fire Door Alliance Scheme Directory

www.firedoors.bwf.org.uk/publications/guides-and-directories/

A series of 18 horizontal dotted lines for taking notes.

The logo for the British Woodworking Federation (BWF) Fire Door Alliance. It features the lowercase letters 'bwf' in a white, sans-serif font. The 'w' is stylized with a vertical bar through it. To the right of the letters is a white icon of a fire door with a flame inside. Below the 'bwf' and the icon, the words 'FIRE DOOR' and 'ALLIANCE' are stacked in a large, bold, white, sans-serif font. The background is a vibrant red with a large, abstract geometric shape in the center composed of several triangles in various shades of red and black.

bWf FIRE DOOR ALLIANCE

Contact:

The British Woodworking
Federation 26 Store Street
London WC1E 7BT
020 7637 2646
firedoors@bwf.org.uk

Note: Whilst every effort has been made to ensure the accuracy of the advice given, the BWF cannot accept liability for loss or damage arising from the use of information supplied in this publication.